

How to Draw and Shade Basic Geometric Forms

Sphere

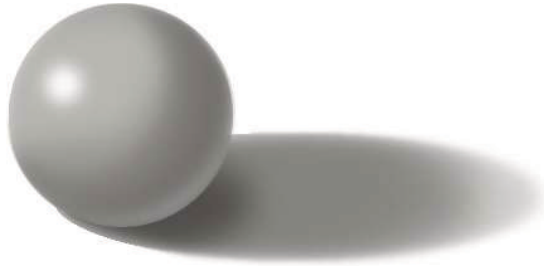

Cylinder



Cone



Pyramid

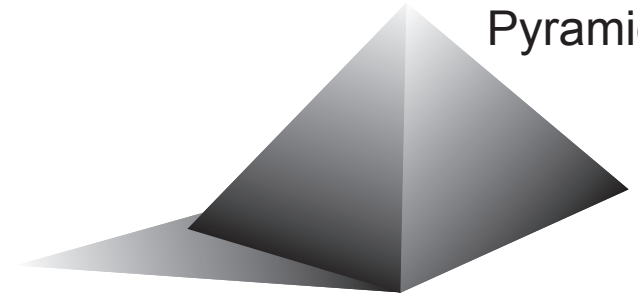

Cube

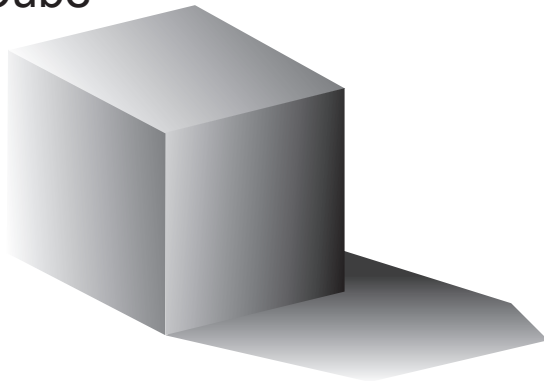

Ring



Donut



Read through
instructions before
beginning.

Drawing Form: The Circle

1. Draw a square:

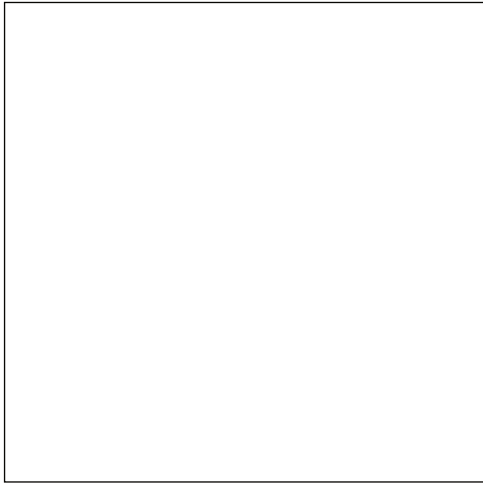

3. Begin sketching circle

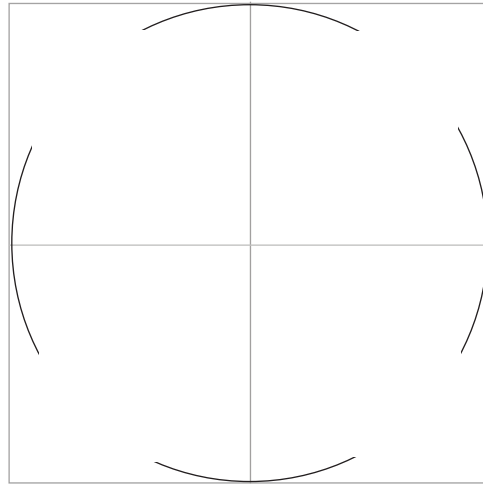

2. Divide square into 4 equal sections

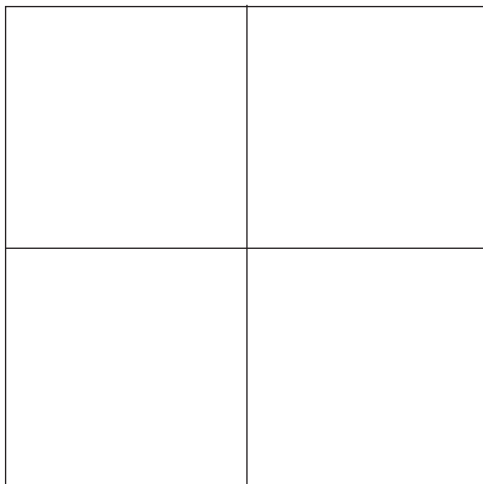

4. Finish circle

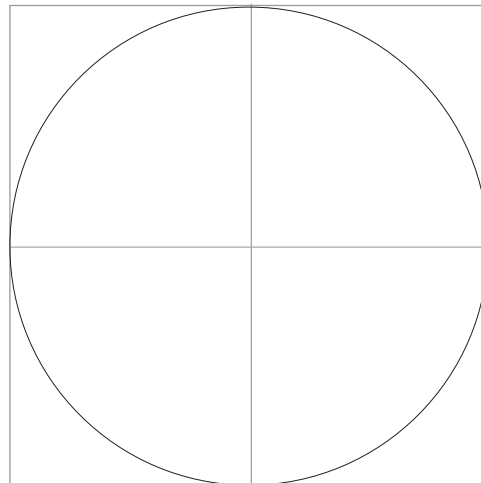

Avoid this. If corners get pointed, erase and try again.

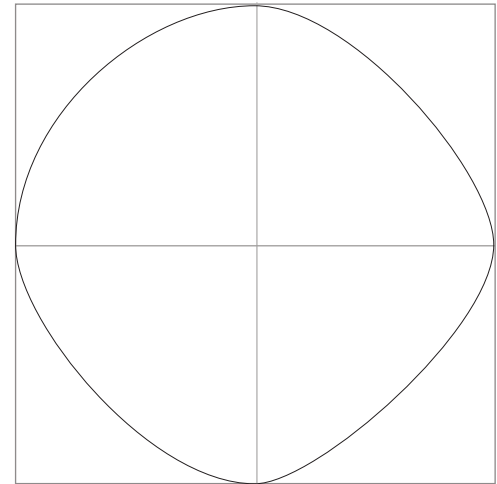

Drawing Form: The Sphere:



Create Value Zones

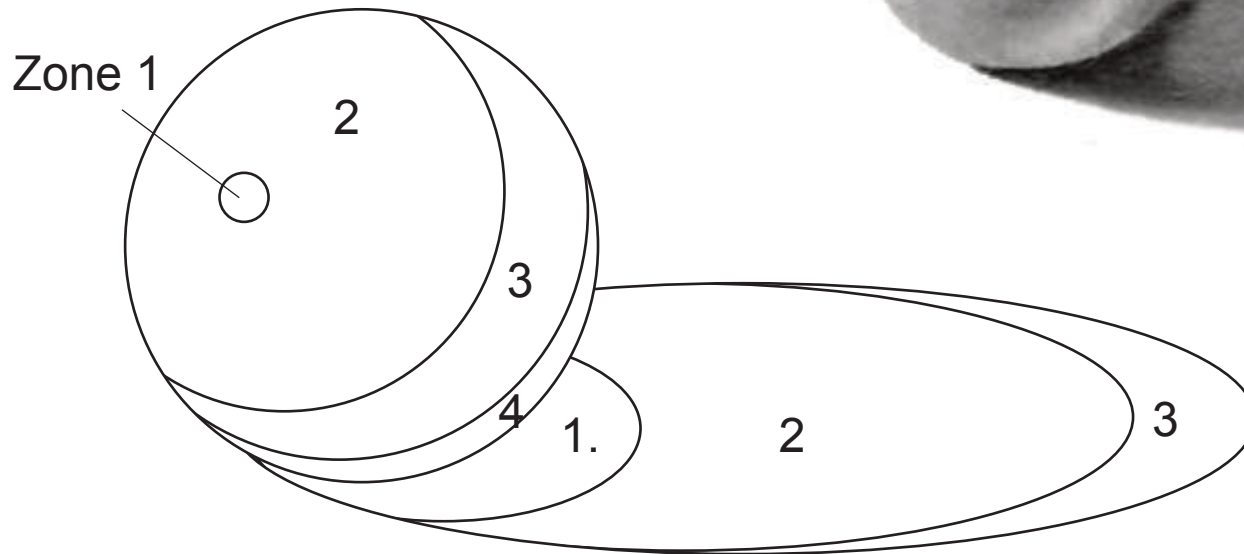

To create Value Zones, simplify a shaded area into separate zones of values.

Drawing Form: The Sphere:

Block in values

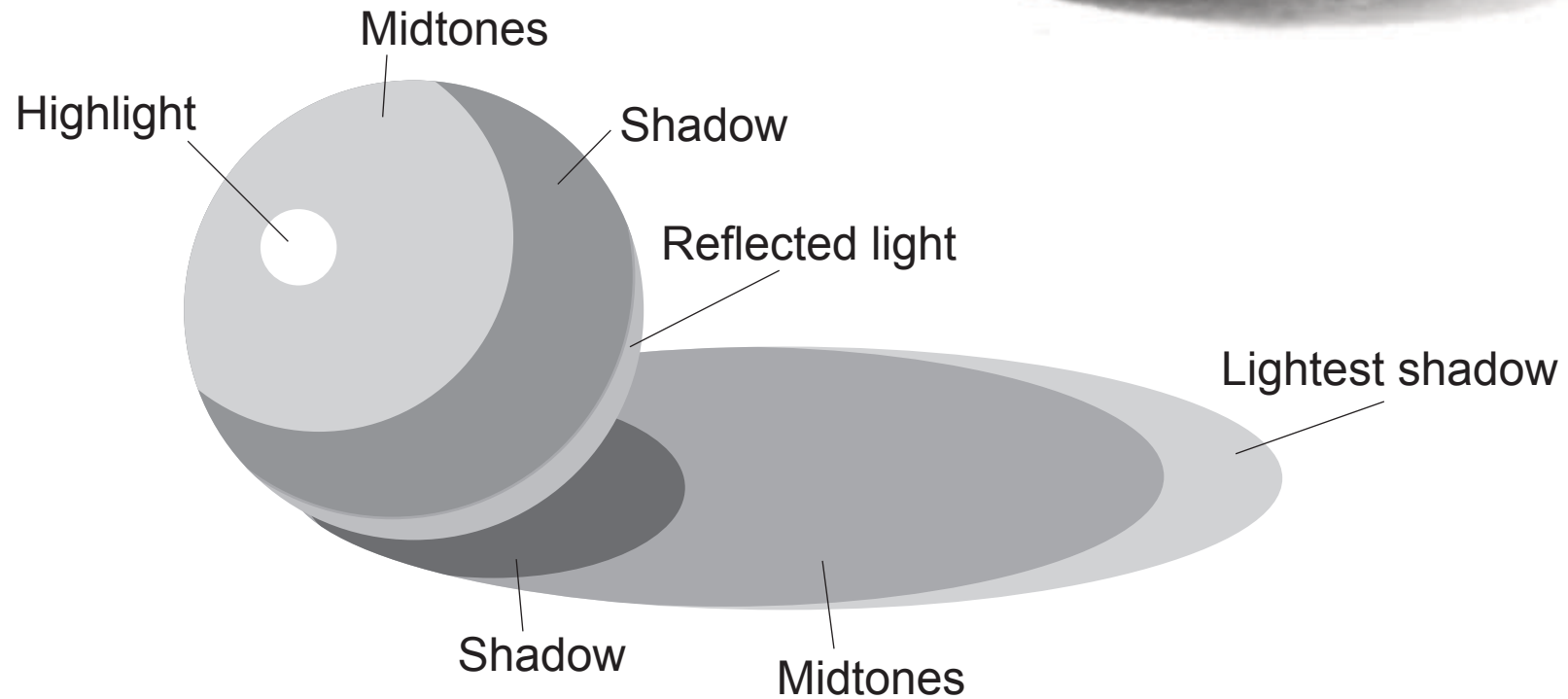

Drawing Form: The Sphere:

Pencil Drawing of
Sphere



Computer Generated
sphere

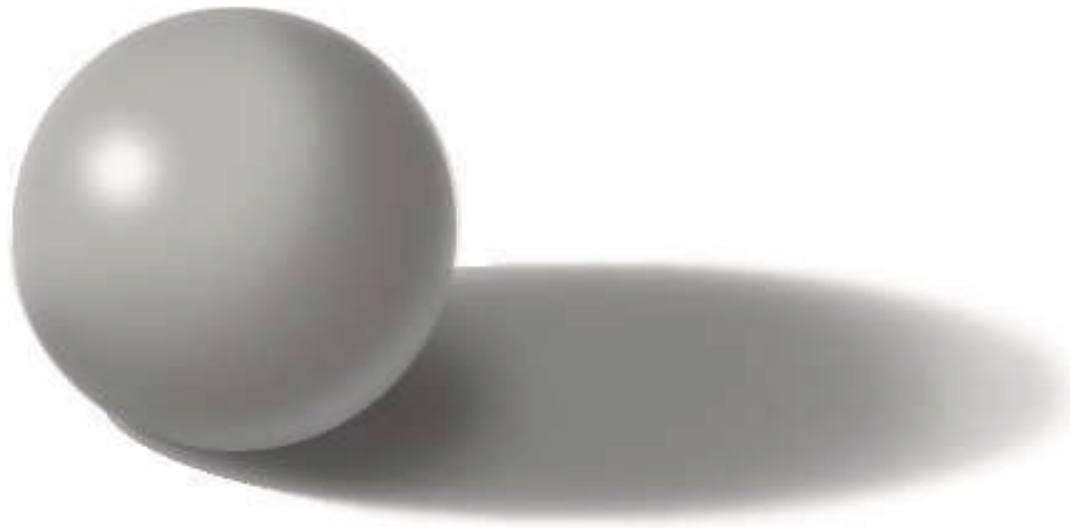

Drawing Form: The Ellipse

Draw a rectangle



Divide Rectangle



Draw ellipse in rectangle

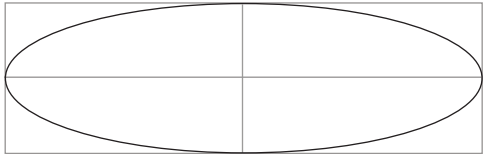

Avoid pointed corners

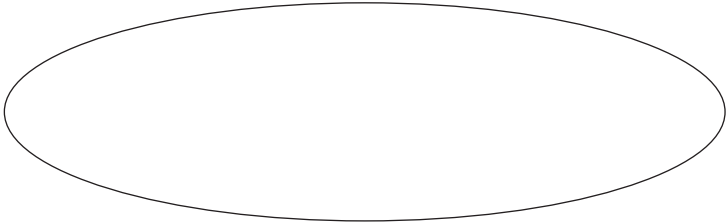
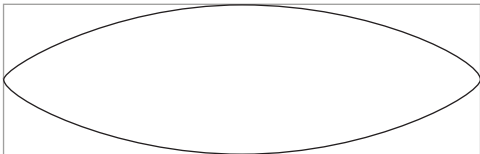

Draw parallel ellipses

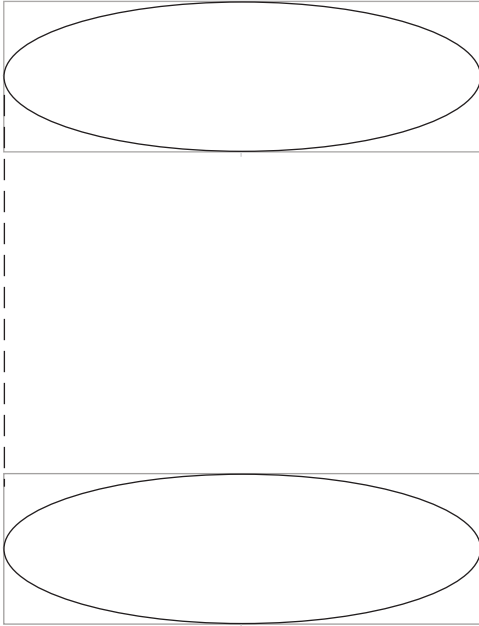

Drawing Form: The Ellipse

Practice Drawing Ellipses at various angles, and various sizes:

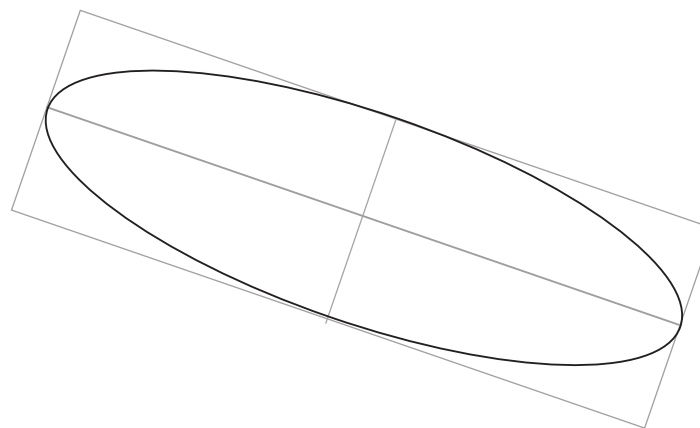
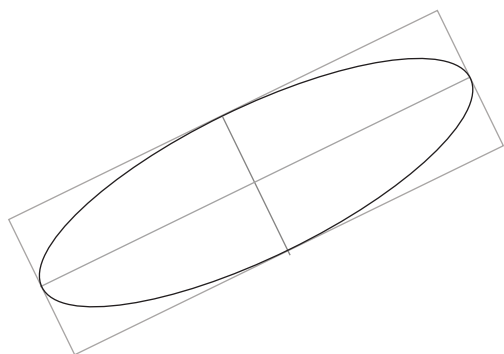

Draw a wide ellipse:

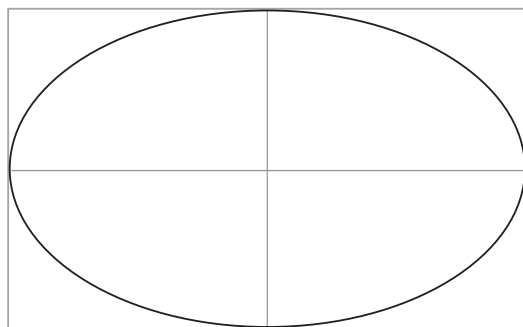

Draw a narrow ellipse:



Drawing Form: The Cylinder



1. Draw two parallel ellipses

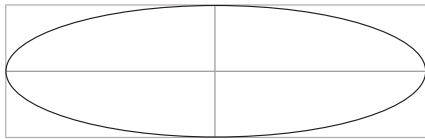
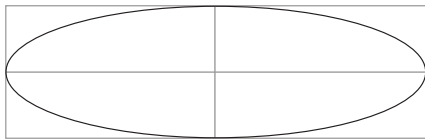

2. Connect ellipses with vertical lines

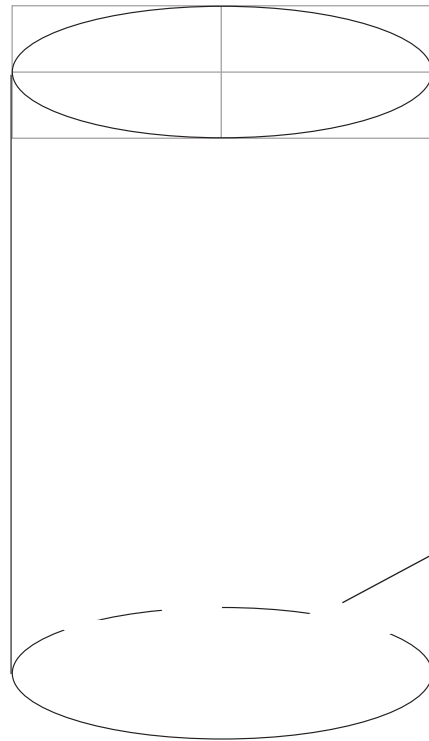

Erase inside ellipse

3. Finished cylinder

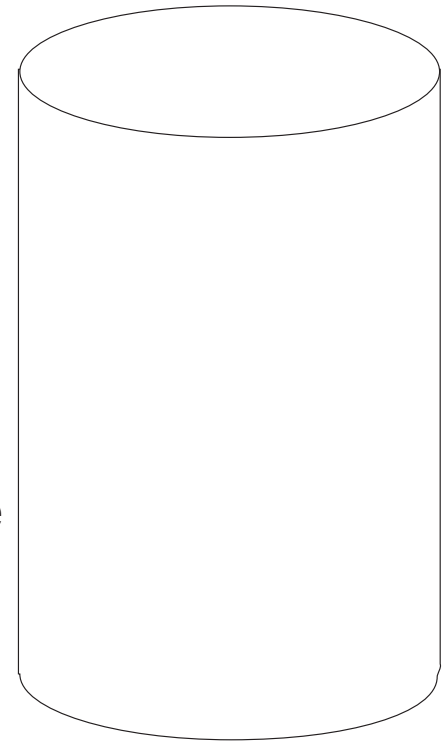

Drawing Form: The Cylinder

Shading Cylinder



Notice that the cylinder has counter gradients



Drawing Form: Shiny Cylinder

Draw a cylinder

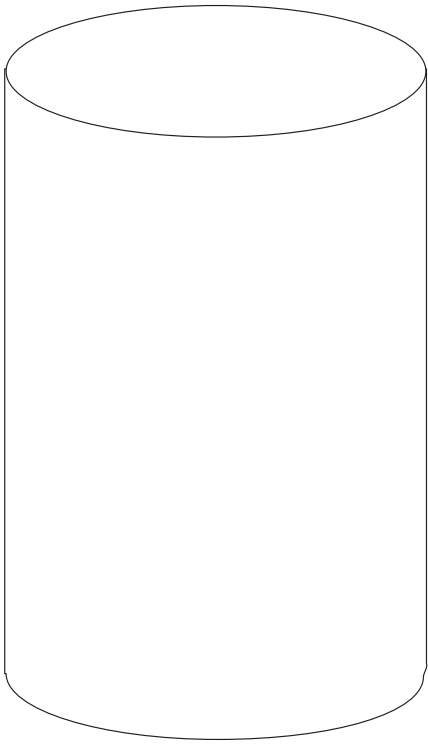

Create value zones
(Review Sphere exercise)

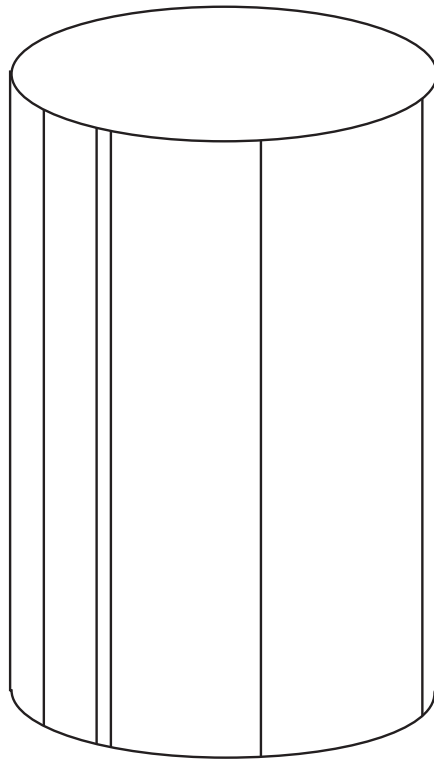

Block in Values from
light to dark

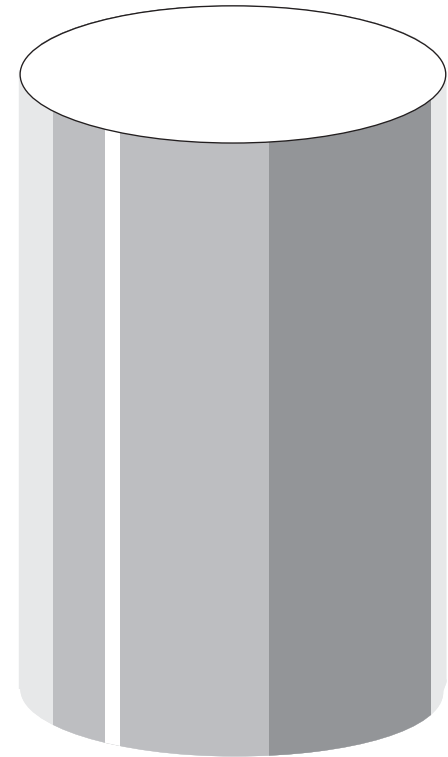

Drawing Form: Shiny Cylinder

Blend Values



For an extra challenge:
Make inside shiny too.



Tip: Don't blend the white highlights. Hard edges make the shine shinier

Drawing Form: The Cone

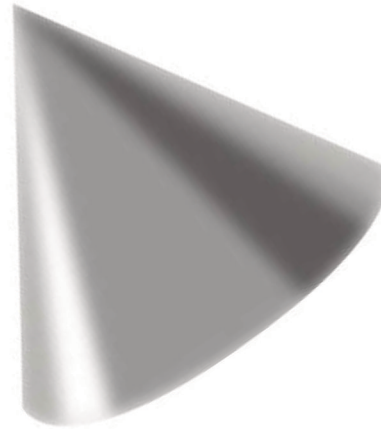

Draw an ellipse and a vertical line:

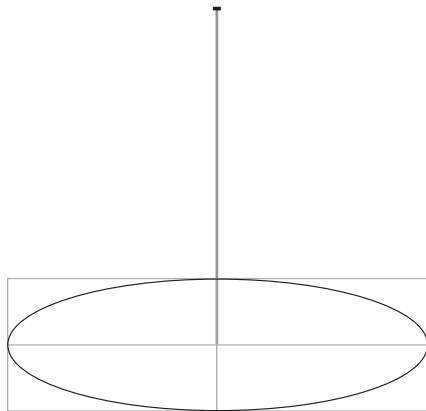

Draw two lines up to the top of the vertical line:

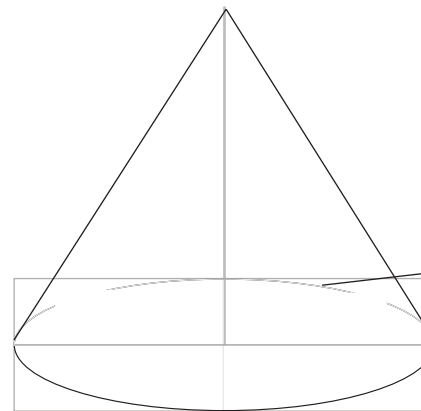

Erase inside of ellipse

Drawing Form: The Cone

Apply a gradient from light on the left to dark on the right:

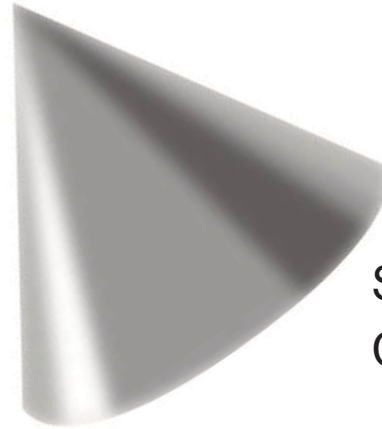

Shiny cone:
Create value shapes:

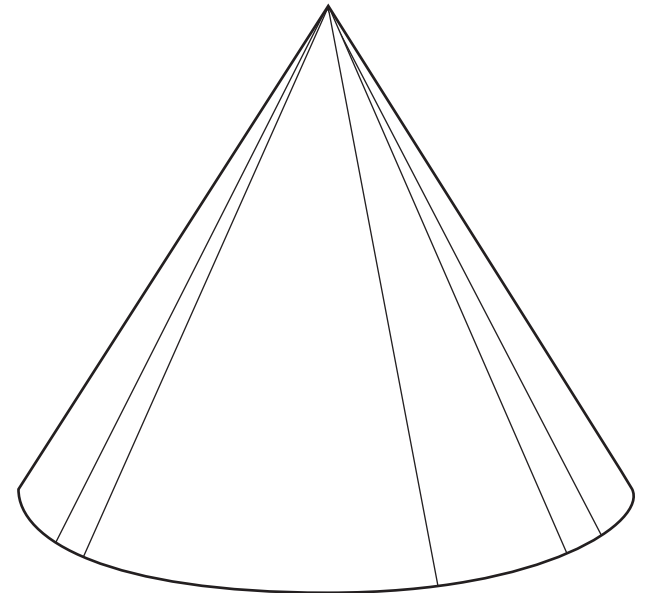

Drawing Form: The Cone

Apply four values:

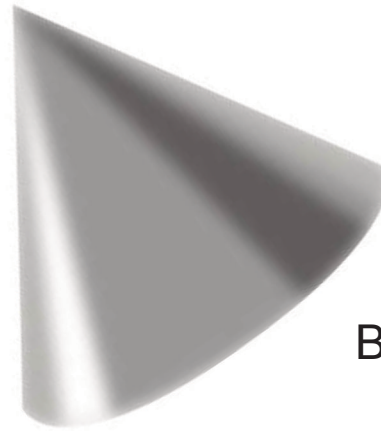

Blend value edges:



Tip: The harder the edges the more shiny it looks

Drawing Form: The Sliced Cone

For an extra challenge try the sliced cone:

Add a tilted ellipse and erase the top of the cone:

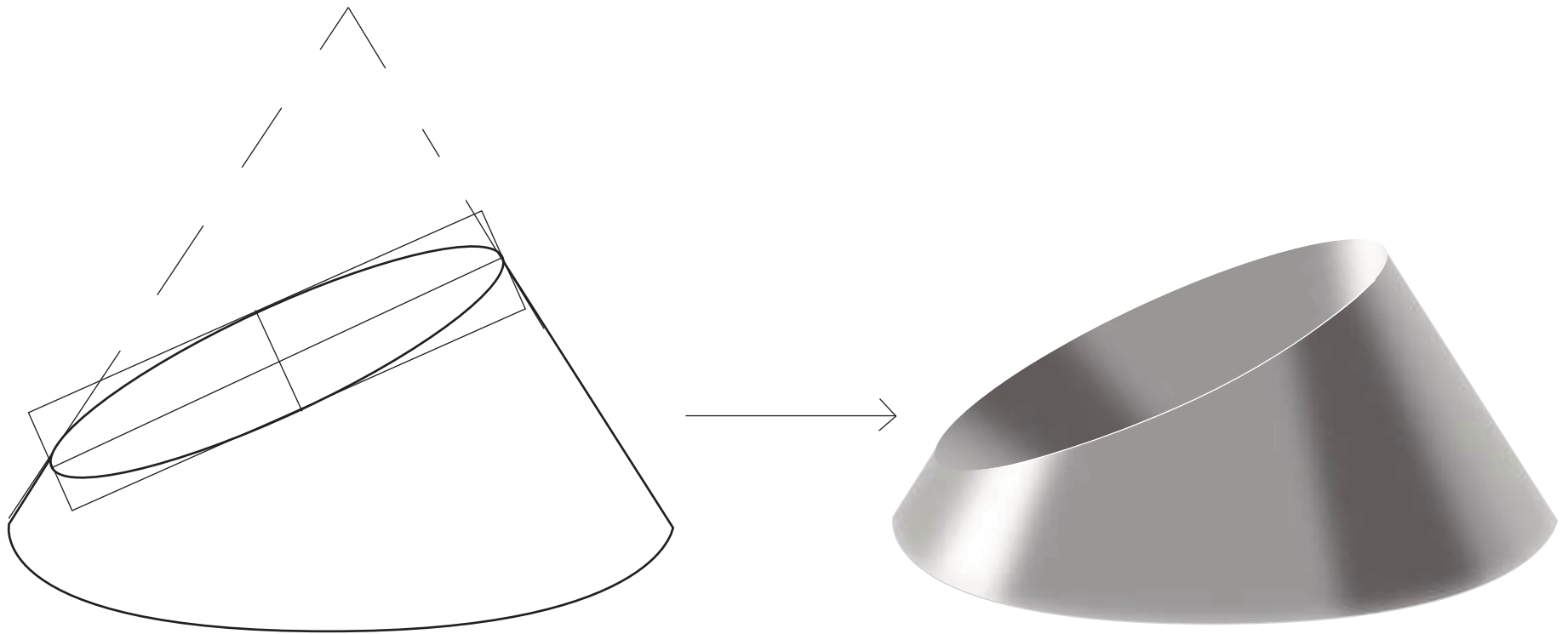

Drawing Form: The Donut



Draw an ellipse within an ellipse:

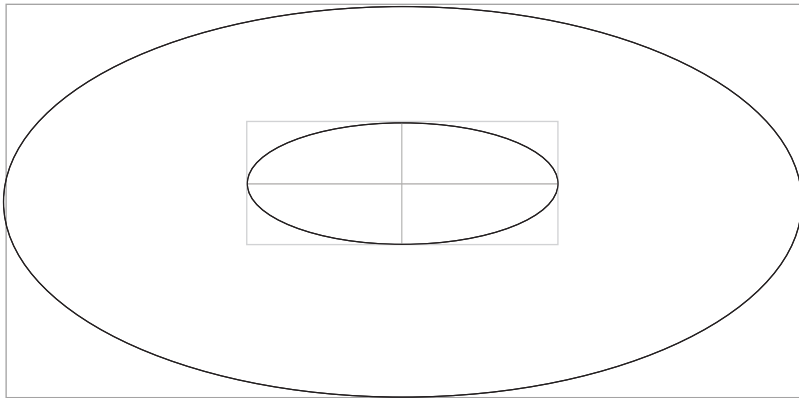

Repeat the front edge below, and widen the sides

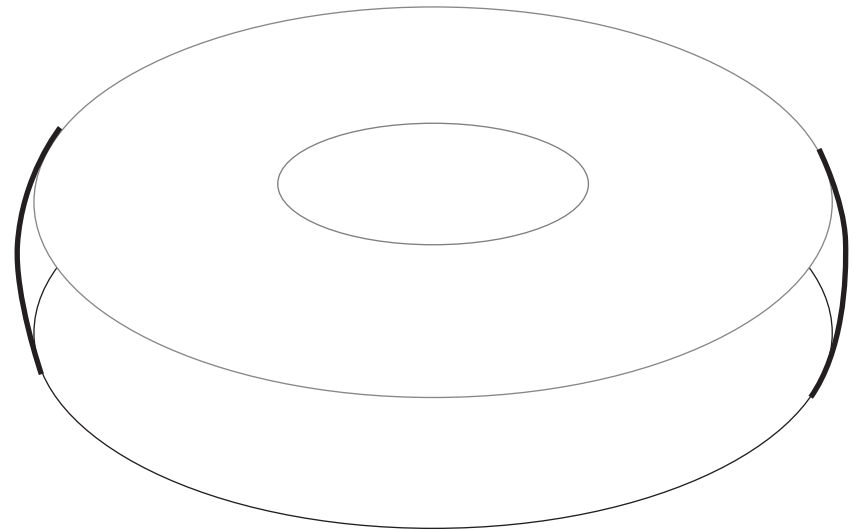

Drawing Form: The Donut

Add value zones:

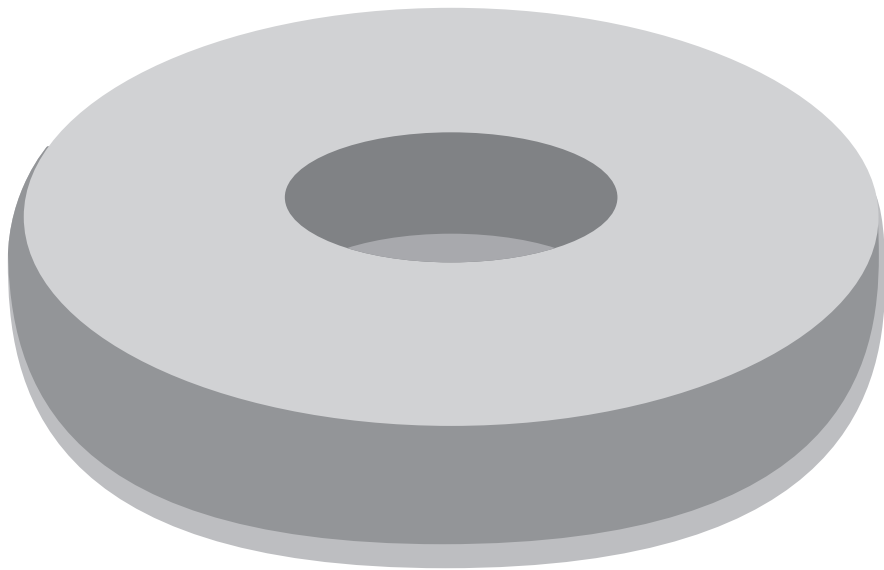

Blend value Zones



Drawing Form: The Cube

Draw a cube use three sets of parallel lines.

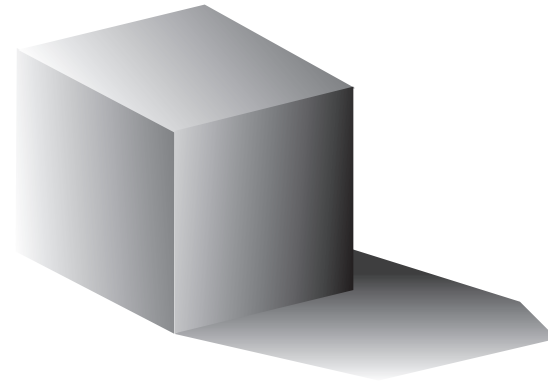

1. Draw three vertical lines:

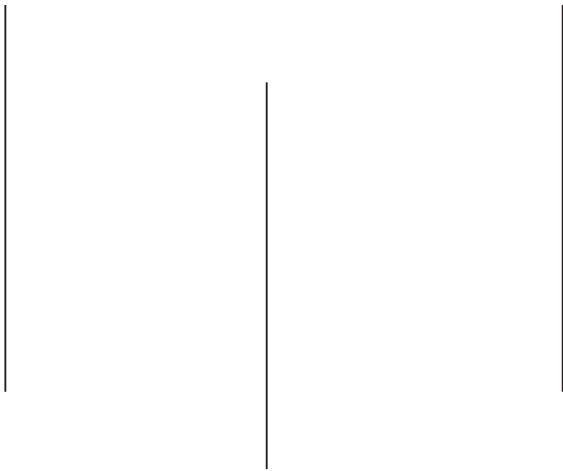

2. Draw three angled lines that are parallel

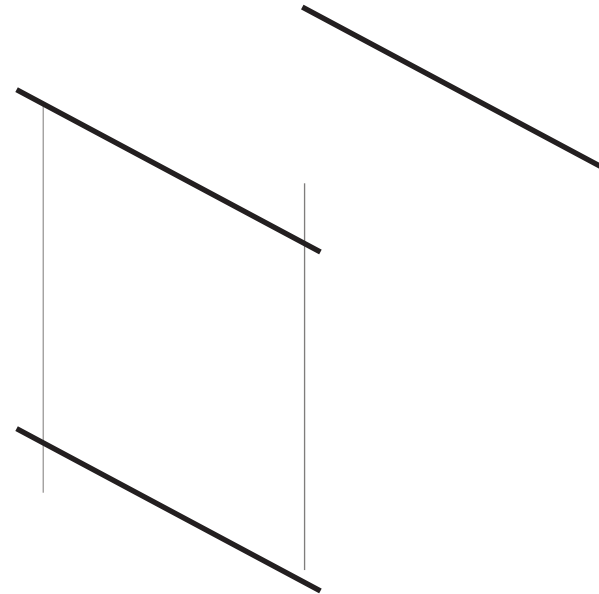

Drawing Form: The Cube

3. Draw final three angled lines that are parallel

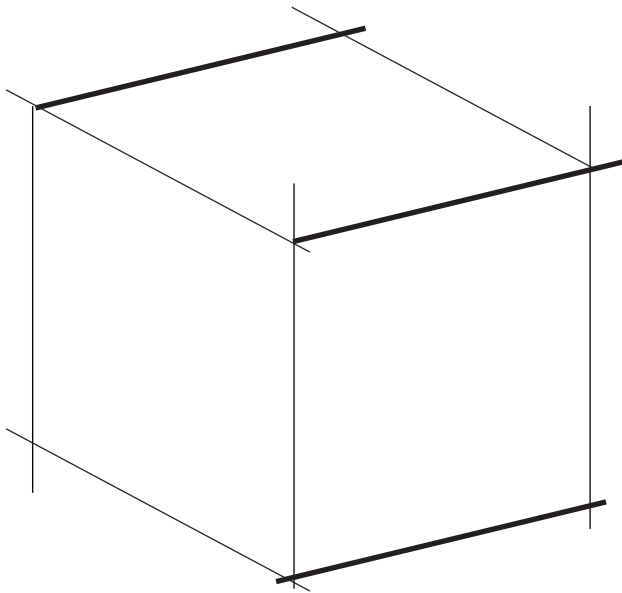

3. Shade in sides with counter gradients, and invent what you think the shadow might look like:

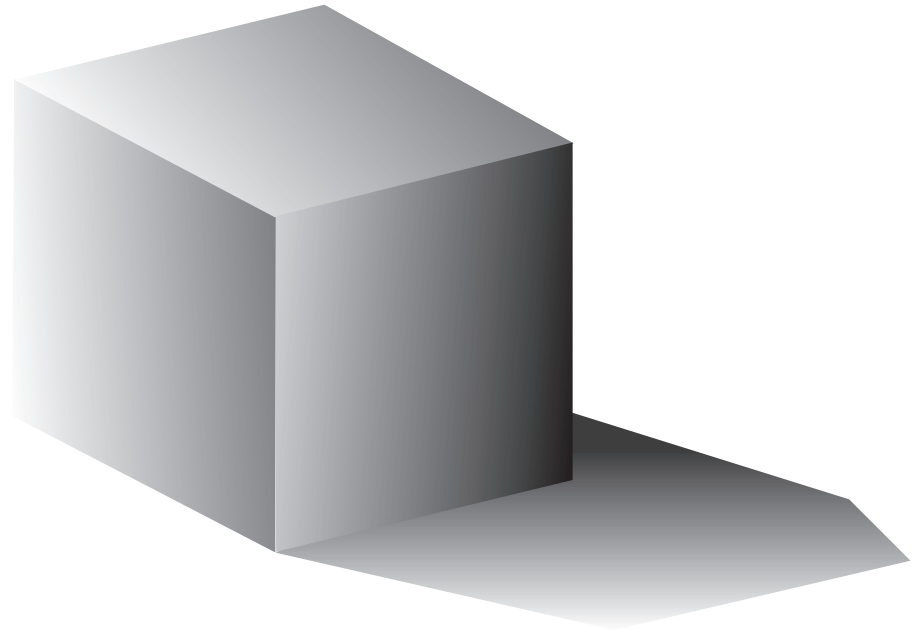

Drawing Form: The Pyramid

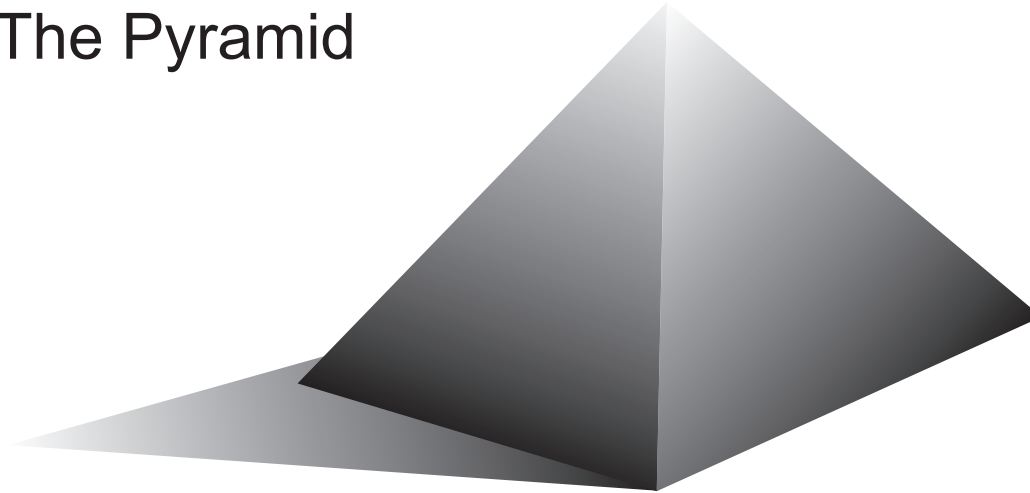

1. Draw two parallel lines:

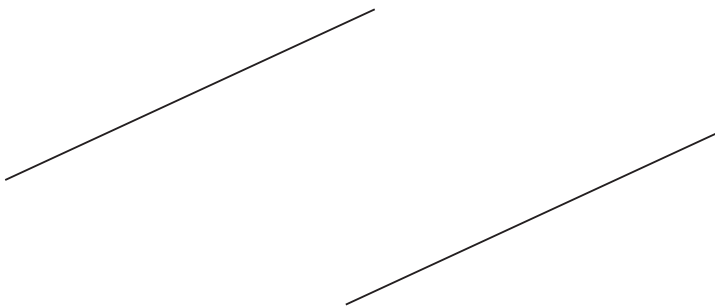

3. Draw two more parallel lines going the other direction::

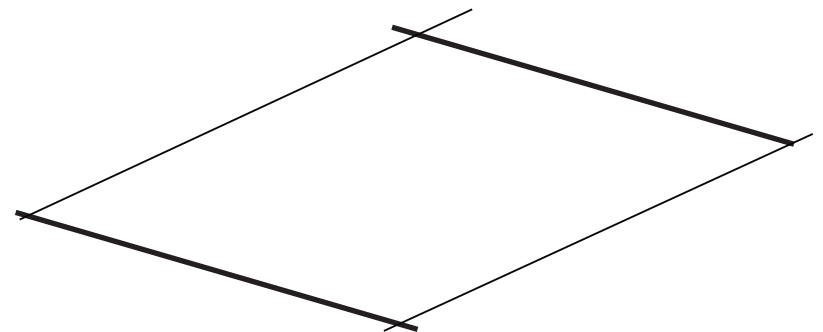

Drawing Form: The Pyramid

4. Find the center of the square by drawing lines through the diagonal corners.

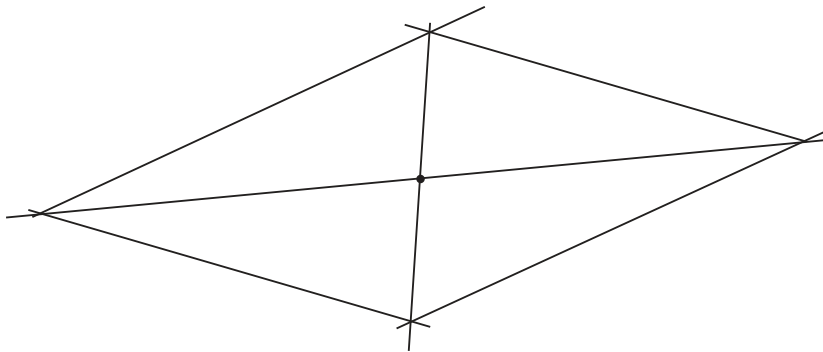

5. Draw a vertical line up from the center point:

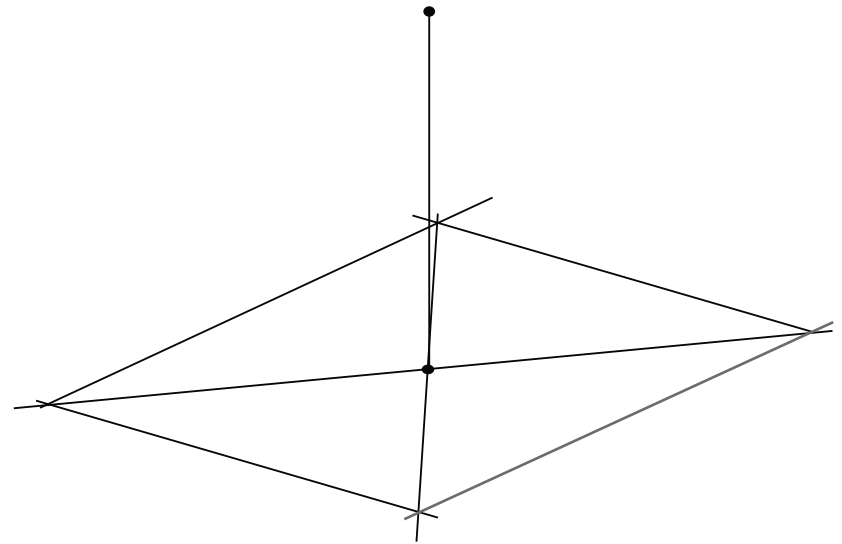

Drawing Form: The Pyramid

6. Draw one side of the pyramid:

7. Draw the other side of the pyramid:

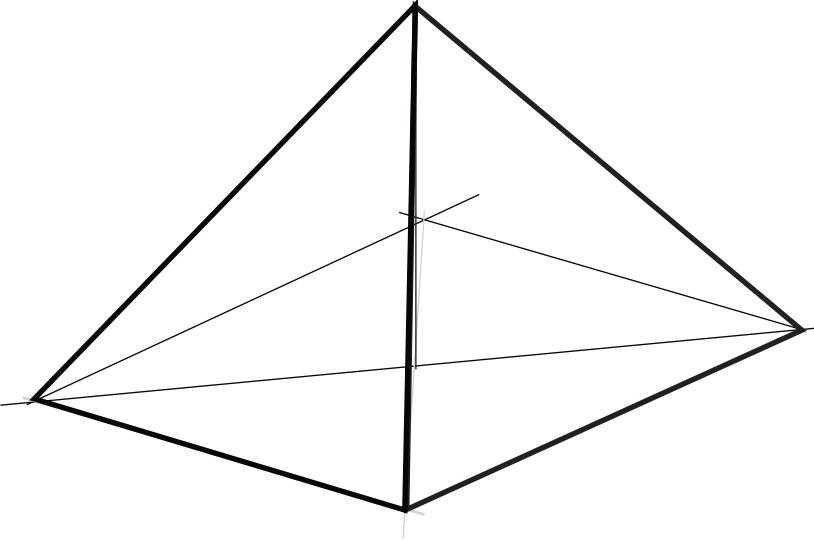
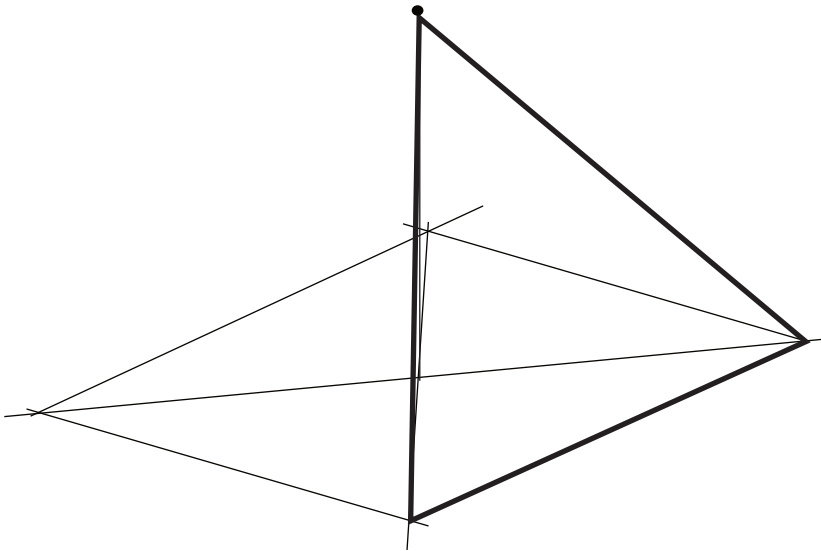

Drawing Form: The Pyramid

7. Erase all unwanted lines:

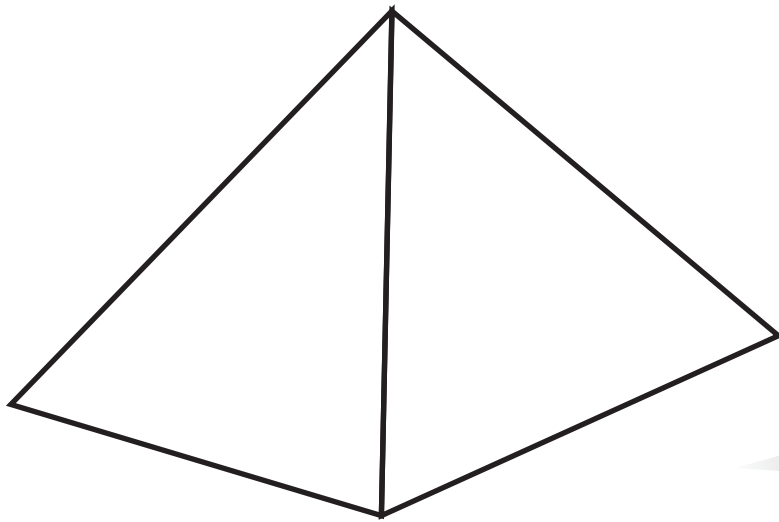

7. Fill in sides with gradients:

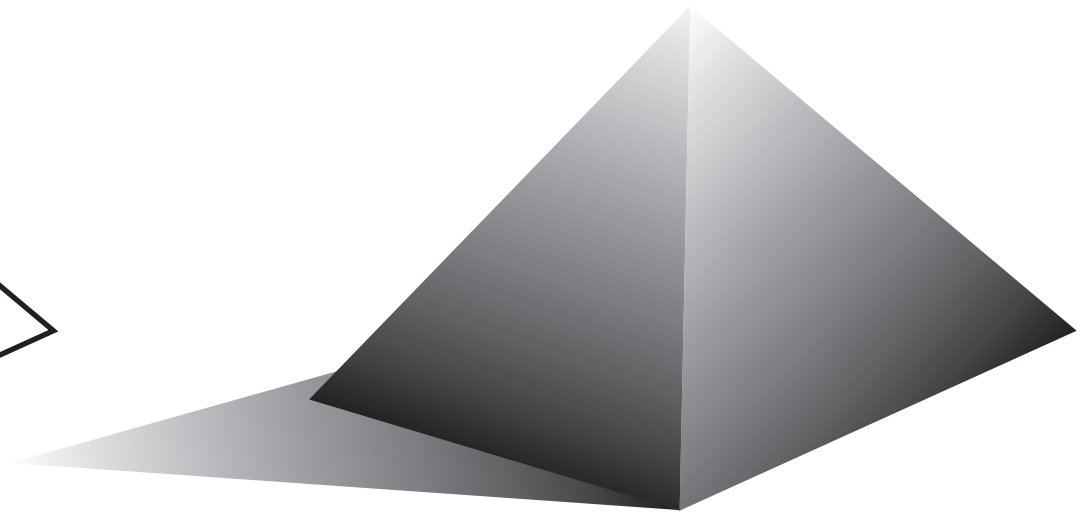

Drawing Form: The Ring

1. Draw an ellipse.
(See page Drawing Form: The Ellipse)

2. Draw another ellipse
next to the first one:

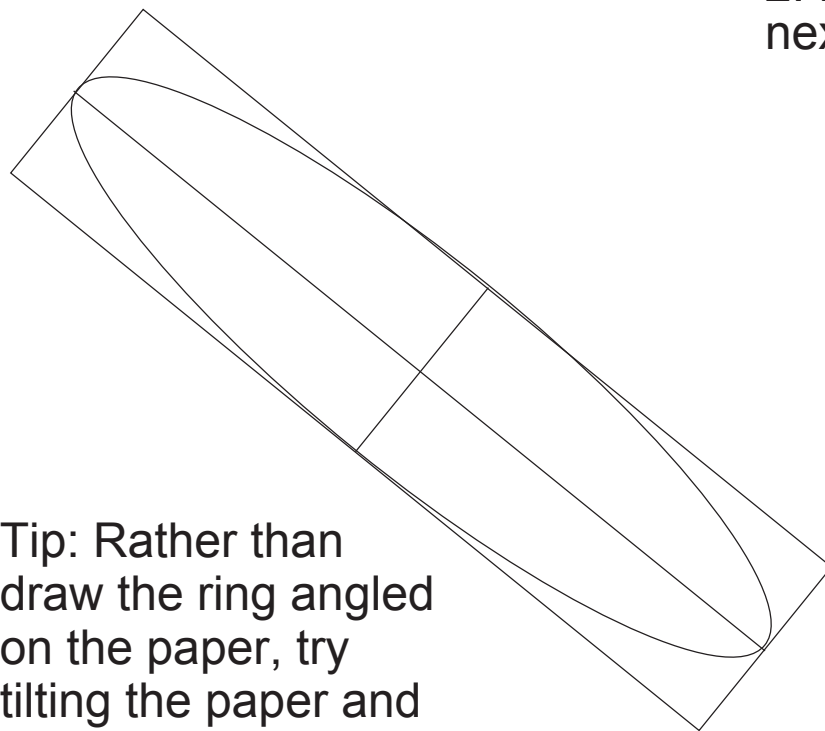

Tip: Rather than draw the ring angled on the paper, try tilting the paper and drawing the ring.

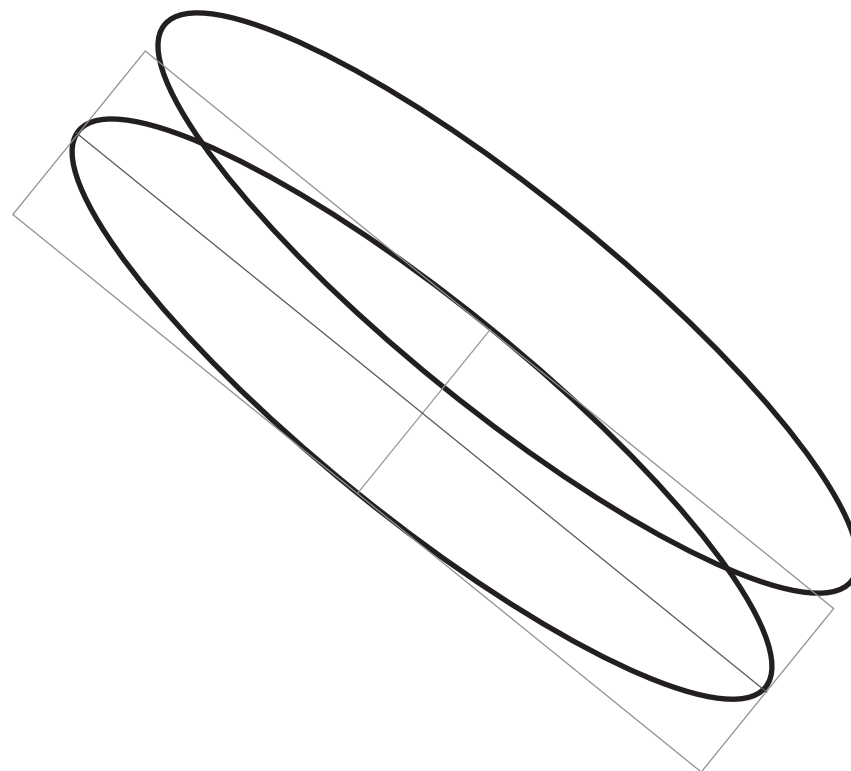

Drawing Form: The Ring

3. Draw lines that connect the sides of the ellipses

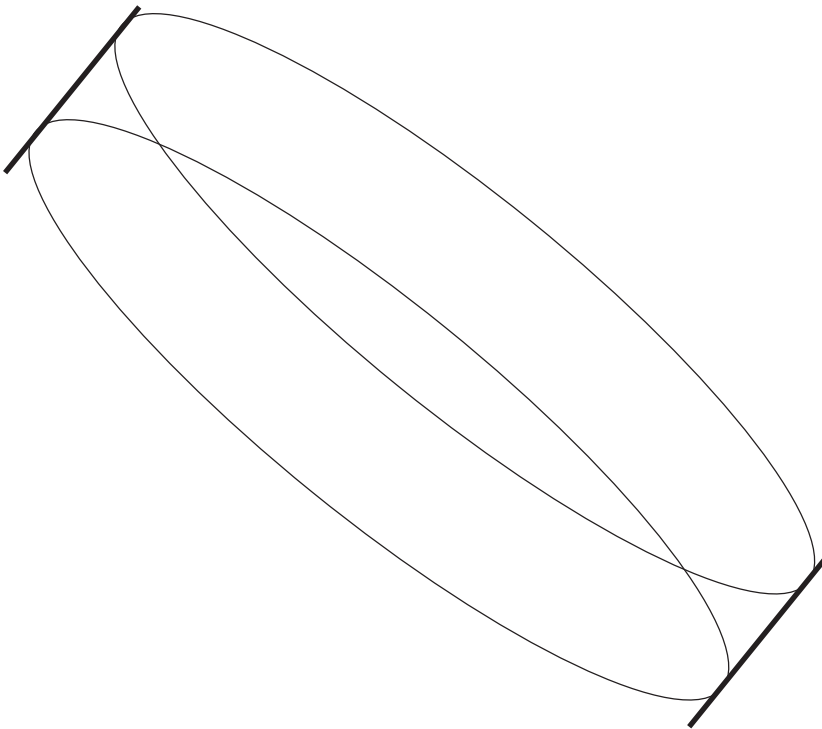

4. Draw an ellipse inside the top ellipse:

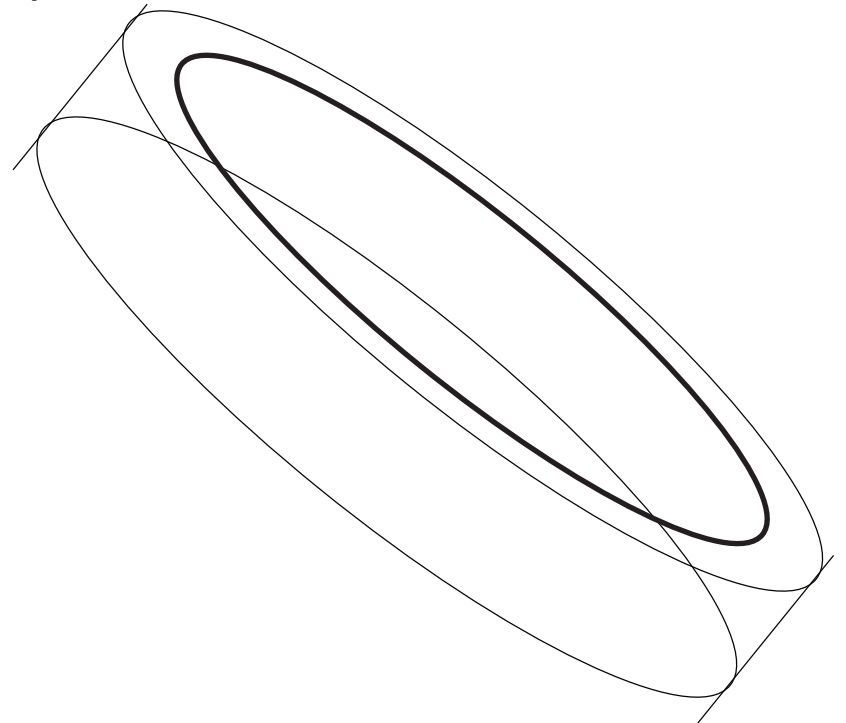

Drawing Form: The Ring

5. Erase unwanted lines:

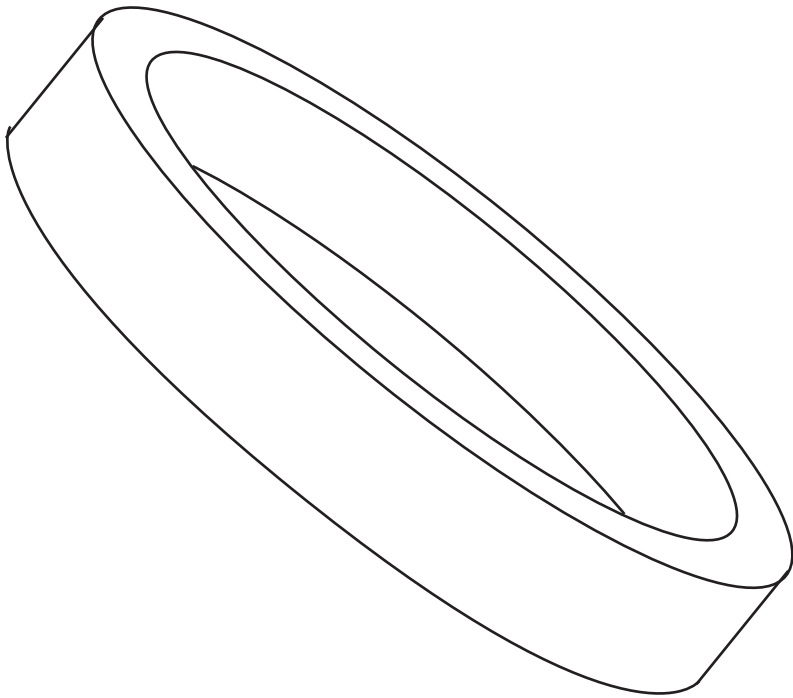

6. Apply gradients:



Drawing Forms: The Ring

For an extra challenge make a shiny ring

7. To make a shiny ring, create value shapes:



7. Blend value shapes. (Tip: let the white highlights have sharp edges, not blended. This make the surface shinier).



Drawing Form: The Optical Illusion

Draw these optical illusions and add gradients. For an extra challenge try adding shiny surfaces:

